

ELEMAX

MOBILE EXTRACTION SYSTEM



Automotive

Workshop equipments



Applications



Ø 75



Ø 100



Ø 125



Ø 150

Terms of use

Exhaust gas extraction system in closed environment without centralized gas extraction systems

DESCRIPTION

ELEMAX mobile extraction systems are designed to solve the problem of extracting exhaust gases in closed environments, which are not equipped with wall or ceiling fixed extraction systems. Once extracted, the gases are evacuated in the external environment through a flexible hose, given as standard equipment. Various models and accessories are designed for a wide range of use in motorcycles, cars, trucks and vehicles workshops.

FEATURES

Trolley structure in powder-coated steel, fitted on a support equipped with wheels. Simple extraction centrifugal fan joined directly with a single phase electric motor (220/1/50) and electrical connection cable (5 m). Extraction nozzle for exhaust gases extraction (possibility of connection to a flexible hose with rubber nozzle, single or twin exhaust).

ADDED VALUES

Gas spring for assisted movement of the extraction chamber and positioning on the exhaust. Interchangeable accessories, in order to allow different applications on different vehicles.

CERTIFICATIONS



TECHNICAL FEATURES

Model	Air flow m ³ /h	Power kW	Voltage V/ph/Hz
ELEMAX	2000	1.1	230/1/50

ELEMAX

MOBILE EXTRACTION SYSTEM

DIMENSIONS

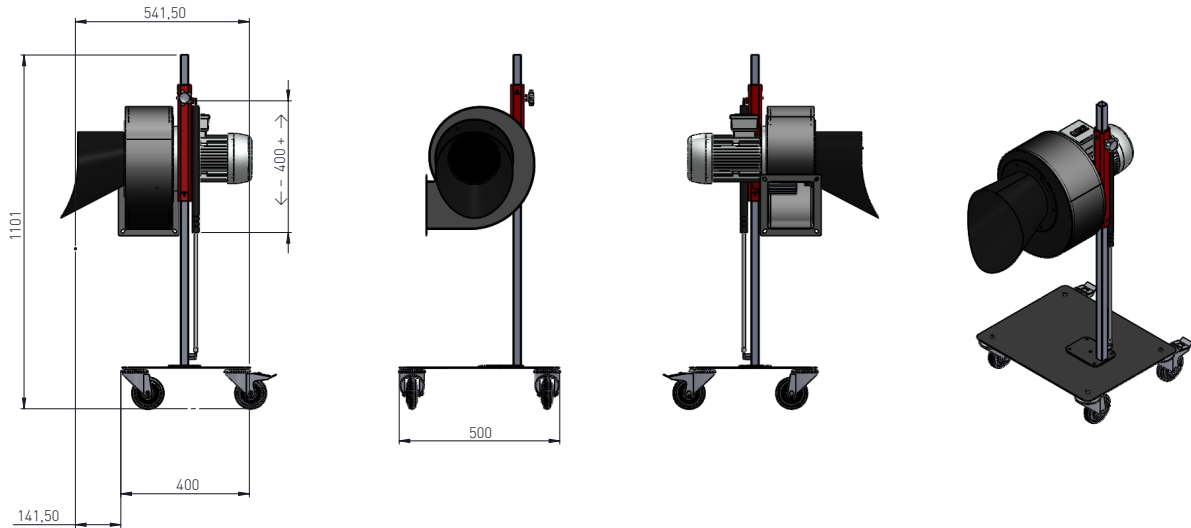

Model	A mm	B mm	C mm	D mm	E mm	G mm	H mm	Ø I mm
ELEMAX	500	566	1020	420	400	344	242	125

PACKAGING

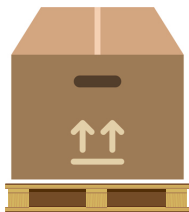

Packaging volume 1 m³
(120x80x105 cm)

ELEMAX EXTRACTION SYSTEM WITH T12K HOSE



Code	Description
ELEMAX00000010	ELEMAX extraction system 1.1 kW - 230/1/50 Hz + T12K Ø 150 mm L. 10 m + extraction nozzle
ELEMAX00000060	ELEMAX extraction system 1.1 kW - 230/1/60 Hz + T12K Ø 150 mm L. 10 m + extraction nozzle



ACCESSORIES



"Y" coupler	Code	Description
-------------	------	-------------



BRV50000000000 Pantograph positioner BRV5 with nozzles Ø 160 mm and 2 flexible hoses TGA Ø 100 - L. 1.25 m

Adapters for ELEMEX	Code	Description
---------------------	------	-------------



50ELE024 Car exhaust gas extraction hood



50ELE028 Adapter for flexible hose Ø 75 mm



50ELE026 Adapter for flexible hose Ø 100 mm



50ELE029 Adapter for flexible hose Ø 125 mm



50ELE027 Adapter for flexible hose Ø 150 mm



50ELE030 Adapter for flexible hose Ø 160 mm



50ELE031 Adapter for double flexible hose Ø 75 mm



50ELE025 "Y" adapter for flexible hose Ø 100mm



ELEMAX

MOBILE EXTRACTION SYSTEM

ACCESSORIES



TGA anti-crush flexible hose	Code	Description
	TGA00750002500	TGA anti-crush flexible hose Ø 75 mm L. 2.5 m
	TGA01000002500	TGA anti-crush flexible hose Ø 100 mm L. 2.5 m
	TGA01250002500	TGA anti-crush flexible hose Ø 125 mm L. 2.5 m
	TGA01500002500	TGA anti-crush flexible hose Ø 150 mm L. 2.5 m

Supply cables for ELEMAX	Code	Description
	DBPZ1F10SCSC0	Power supply cable c/w plug 230 V 3x2.5 - L. 10 m and adapter Schuco - Cee
	DBPZ1F20SCSC0	Power supply cable c/w plug 230 V 3x2.5 - L. 20 m and adapter Schuco - Cee
	DBPZ1F10SCIND	Power supply cable c/w plug 230 V 3x2.5 - L. 10 m and blue industrial plug 16 A
	DBPZ1F20SCIND	Power supply cable c/w plug 230 V 3x2.5 - L. 20 m and blue industrial plug 16 A

SPARE PARTS

Flexible hose	Code	Description
	T12K0100000152	Expulsion flexible hose for ELEMAX Ø 152 mm - L. 10 m

Code	Description
DBRUOTARGVM11	Castor M10 with brake
COM00090	Gas spring
RICOELEMAX0010	Replacement kit - extractor fan including cables